



# Dolphin PCI Express MXH918 Adapter



MXH918 NTB Adapter Users Guide

Version 1.0

Date: 05<sup>th</sup> August 2024

## Table of Contents

<b>1. DISCLAIMER</b> .....	<b>4</b>
<b>2. TERMS AND ACRONYMS</b> .....	<b>5</b>
<b>3. TECHNICAL INFORMATION</b> .....	<b>5</b>
3.1 BOARD REVISION HISTORY .....	5
3.2 HIGH-LEVEL SPECIFICATION .....	6
3.3 SIMPLIFIED SCHEMATICS .....	7
3.4 PCI SLOT DETERMINATION .....	7
3.5 AIRFLOW - OPERATING ENVIRONMENT .....	7
<b>4 INSTALLATION</b> .....	<b>8</b>
4.1 BOARD UNPACKING .....	8
4.2 PRE-INSTALLATION QUESTIONS .....	8
4.3 CHANGE PCI BRACKET .....	8
4.4 CONFIGURE THE BOARD .....	9
4.5 INSTALL THE ADAPTER CARD .....	9
4.6 INSTALLING AND REMOVING THE CABLE .....	9
4.6.1 <i>Connecting the Cable</i> .....	9
4.6.2 <i>Cable strain relief</i> .....	9
4.6.3 <i>Disconnecting the Cable</i> .....	9
4.7 INSTALLING THE DOLPHIN EXPRESSWARE SOFTWARE .....	10
4.8 VERIFY INSTALLATION & LEDs .....	10
<b>5 OPERATION</b> .....	<b>11</b>
5.1 CONFIGURATION AND DIP SWITCH .....	11
5.2 DIP SWITCH NTB SETTINGS .....	11
5.3 USE CASES .....	12
5.3.1 <i>Host Transparent Hot Add</i> .....	12
5.3.2 <i>Two-Node NTB Network</i> .....	12
5.3.2 <i>Three-Node NTB Network</i> .....	12
5.3.3 <i>Multiple-Node Network</i> .....	13
5.4 FIRMWARE UPGRADE .....	13
5.5 IDENTIFYING THE CARD .....	13
<b>6 PCI CABLE PORT</b> .....	<b>15</b>
6.1 PCI CABLE SIGNALS .....	15
6.2 PCI CABLE CONNECTOR X8 PIN-OUT .....	15
<b>7 COMPLIANCE AND REGULATORY TESTING</b> .....	<b>16</b>
7.1 EMC COMPLIANCE .....	16
7.2 FCC CLASS A .....	16
7.3 ROHS COMPLIANCE .....	16
7.4 WEEE NOTICE .....	16
<b>8 LIMITED WARRANTY</b> .....	<b>17</b>
8.1 WARRANTY PERIOD .....	17
8.2 COVERAGE .....	17

---

8.3	SERVICE PROCEDURE.....	17
<b>9</b>	<b>SUPPORT .....</b>	<b>17</b>
Figure 1:	MXH918 Simplified Schematics .....	7
Figure 2:	Full length PCIe bracket .....	8
Figure 3:	DIP Switch (Shipping Default) .....	11
Figure 4:	Host Transparent Hot Add .....	12
Figure 5:	Two-Node Network .....	12
Figure 6:	Three-Node Network.....	12
Figure 7:	Multiple Node Network .....	13
Table 1:	Revision History .....	5
Table 2:	MXH918 Product High-Level Specifications .....	6
Table 3:	LED behaviors .....	10
Table 4:	DIP Switch Transparent settings for MXH918 .....	11
Table 5:	PCIe Cable Port Signals .....	15
Table 6:	External PCIe x8 cable pin-out .....	15

## 1. DISCLAIMER

DOLPHIN INTERCONNECT SOLUTIONS RESERVES THE RIGHT TO MAKE CHANGES WITHOUT FURTHER NOTICE TO ANY OF ITS PRODUCTS TO IMPROVE RELIABILITY, FUNCTION, OR DESIGN.

DO NOT USE THE INFORMATION IN THIS GUIDE TO DESIGN YOUR PCI-SIG-COMPLIANT PRODUCT; ALWAYS REFERENCE THE ORIGINAL PCI-SIG SPECIFICATION FOR DETAILS.

TO THE FULLEST EXTENT PERMITTED BY LAW, DOLPHIN WILL NOT BE LIABLE FOR ANY INDIRECT, INCIDENTAL, SPECIAL OR CONSEQUENTIAL DAMAGES (INCLUDING LOST PROFITS, LOST DATA, OR LOSS OF USE) ARISING OUT OF ANY USE OF DOLPHIN'S PRODUCTS, SOFTWARE OR SERVICE PROVIDED. DOLPHIN'S MAXIMUM LIABILITY WILL NOT EXCEED THE TOTAL AMOUNT PAID FOR THE PRODUCT BY THE PURCHASER.

### **LIFE SUPPORT POLICY**

DOLPHIN INTERCONNECT SOLUTIONS' PRODUCTS ARE NOT AUTHORIZED FOR USE AS CRITICAL COMPONENTS IN LIFE SUPPORT DEVICES.

### **ENVIRONMENTAL POLICY**

Dolphin is minimizing the amount of printed documentation and software CDs in its shipments; please download additional documentation and software from [www.dolphinics.com](http://www.dolphinics.com).

## 2. Terms and acronyms

The following are Essential terms and acronyms used in this manual.

<b>CMI</b>	Cable Management Interface. A PCIe cable connects the 2-wire management interface for communication between subsystems. The PCI-SIG External Cabling Specification, version 3.0 or newer, provides more details.
<b>eXpressWare</b>	Dolphin's software stack for PCIe clustering and IO. Please visit <a href="http://www.dolphinics.com/software">www.dolphinics.com/software</a> for more information.
<b>Host mode</b>	The card is installed in a root complex/host PC.
<b>Lane</b>	One PCI Express Lane contains a differential pair for transmission and a differential pair for reception.
<b>Link</b>	A collection of one or more PCI Express Lanes provides the communication path between an Upstream and Downstream Port.
<b>PCIe 4.0 cable</b>	Cable compliant with the preliminary PCI-SIG External Cabling Specification 4.0. Support for CMI.
<b>Port</b>	PCIe Cable port. The MXH918 x8™ or standard PCI Express cable. A single x8 cable connects to another PC with an MXH918 or Dolphin Switch MXS924.

## 3. Technical Information

### 3.1 Board revision history

The following table gives a general overview of the hardware revision history. For details, please consult the MXH918 PCN available from Dolphin.

Adapter card revision	Capabilities
MXH918-AA	<ul style="list-style-type: none"> <li>Initial product version</li> </ul>

**Table 1: Revision History**

## 3.2 High-Level Specification

The table presented below provides an overview of the high-level specifications.

PCI Express	<ul style="list-style-type: none"> <li>➤ Base Specification 4.0</li> <li>➤ External Cabling Specification 4.0</li> <li>➤ Card Electromechanical Specification 4.0</li> </ul>			
Application Performance	<ul style="list-style-type: none"> <li>➤ ~500ns latency (application to application)</li> <li>➤ About 14 GBytes/s throughput (system dependent)</li> </ul>			
Active Components	Microchip Switchtec® Gen4 PFX Switch			
Max Link Speeds	128 GT/s (16.0 GT/s per lane signaling)			
Configuration	DIP-switch			
Topologies	<ul style="list-style-type: none"> <li>➤ One and Two-node direct cable</li> <li>➤ Three-node direct cable</li> <li>➤ Multi-Node Switch (MXS924)</li> </ul>			
Cable Connections	<ul style="list-style-type: none"> <li>➤ SFF-8644 connector for copper/fiber cables</li> <li>➤ Supports double x4 Connector.</li> <li>➤ PCIe 4.0 copper, up to 4m</li> <li>➤ PCIe 4.0 fiber, up to 100m</li> </ul>			
Power	Power Rail	Typical Current	Maximum Current	
	+3.3V	1.0 A	0A	
	+12V	1.0 A	1.53 A	
Cable Clocking Mode	SRNS. SRIS optional.			
Flash	for boot-up configuration data			
EEPROM	Card-specific information (serial number, etc.)			
Host Clock	Host clock isolation supports the Constant Frequency Clock (CFC) or Spread Spectrum Clock (SSC) for the EDGE reference clock.			
Operating Environment	Operating Temperature: 0°C to 55°C (32°F - 131°F) Operating Humidity:5% - 95% non-condensing			
Altitude vs Temperature	<b>250 LFM</b>		<b>350 LFM</b>	
	45 (°C)	3000m	55 (°C)	3000m
	35 (°C)	4500m	45 (°C)	4500m
	25 (°C)	6000m	35 (°C)	6000m
Storage Environment	Storage Temperature: -40°C to 70°C (-40°F to 158°F) Relative Humidity 95% (non-condensing) at 35°C			
Form Factor Dimension	PCIe Half-Length, Half-Height 116.23mm (4.57 inches) x 68.90 mm (2.731 inches).			
eXpressWare support	<ul style="list-style-type: none"> <li>➤ Super Sockets Berkley Sockets API</li> <li>➤ Microsoft WinSock2/LSP support</li> <li>➤ IP Network driver</li> <li>➤ SISI API</li> <li>➤ Smart IO</li> </ul>			
Usage Mode	Non-transparent bridging (NTB) Host			
Operating Systems	Windows, Linux and RTX			
Compliance	<ul style="list-style-type: none"> <li>➤ CE Mark</li> <li>➤ FCC Class B</li> <li>➤ UL94V-0 compliant</li> <li>➤ RoHS Compliant</li> <li>➤ Reach Compliant</li> </ul>			
Mounting Brackets	<ul style="list-style-type: none"> <li>➤ Full height bracket installed.</li> <li>➤ The half-height bracket is included with a board shipping box.</li> </ul>			

**Table 2:MXH918 Product High-Level Specifications**

### 3.3 Simplified schematics

The figure below shows the MXH918 simplified schematics with main functions.

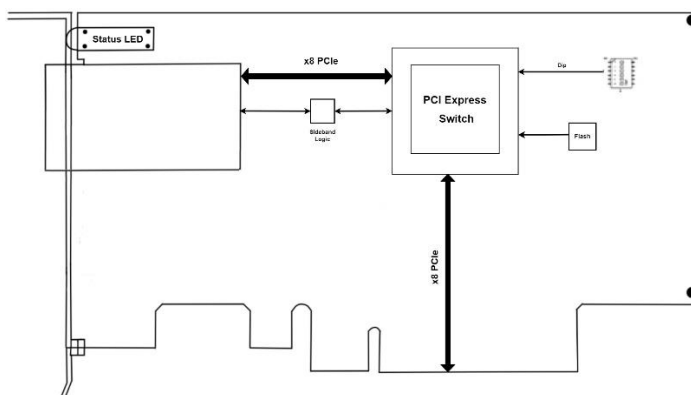

Figure 1: MXH918 Simplified Schematics

### 3.4 PCIe Slot Determination

The MXH918 supports PCIe Gen 1.0, Gen 2.0, Gen 3.0, and Gen 4.0 speeds and x1, x2, x4, and x8 slot edge link widths. The slot width and speed affect the card's performance. The card can be installed in an x8 or x16 connector. The card will auto-configure the slot speed and width.

- Install the board in a slot connecting directly to the CPU for optimal shared memory performance.

### 3.5 Airflow - Operating Environment

To maximize the product's lifetime and maintain the warranty, specify the operating temperature and ensure the specified airflow is present. Consider Special care when using MXH918 in office-type cabinets with poor cooling in combination with other high energy-consuming PCIe devices, e.g., not active cooled GPUs:

- Operating Temperature: 0°C - 55°C (32°F - 131°F),
- Airflow: 350 LFM

**TIP:** Please use the `dis_diag` tool immediately after software installation to verify the temperature. If the chip temperature reported by `dis_diag` exceeds 95°C, it is recommended to improve airflow.

## 4 Installation

For installation, follow these steps from 4.1 to 4.7 sequentially.

### 4.1 Board Unpacking

The MXH918 includes the following components.

- MXH918 Adapter Board with high profile PCIe bracket mounted.
- Low profile PCIe bracket.
- Anti-static bag.
- Getting started guide with serial number for quick Dolphins eXpressWare PCIe software download.

The MXH918 card is delivered in an anti-static bag to avoid any potential damage from static electricity. It is crucial to exercise anti-static precautions before removing the card from the packaging. Clothing or the surrounding work environment can generate static electricity, which may harm the PCI Express adapter card or the PC. Wearing a grounded anti-static wrist strap when opening the PC and handling the MXH918 after taking it out of the anti-static bag is recommended.



### 4.2 Pre-Installation Questions

Before installing the MXH918, it is essential to identify the necessary configuration requirements through specific steps.

- Which system and PCIe slot are suitable for installing the card?
- What is the speed and link width of the selected slot?
- What are the environmental conditions where the card will be installed?
- What type and length of cables will be used?
- How to ensure adequate operational conditions, including temperature and airflow

### 4.3 Change PCIe Bracket

The MXH918 package comes with both High and low-profile PCI Express brackets. The board is initially installed with a standard bracket. To switch to the low-profile bracket, carefully unscrew the two mounting screws to remove the full-height bracket. Remember to save the screws and replace the bracket with the low-profile one.

Before proceeding with the installation process, ensure you are correctly grounded to prevent static discharges that can damage the adapter card. Use the two mounting screws to install the low-profile bracket and be cautious not to overtighten them. Tighten the screws carefully while ensuring that they are appropriately secured.

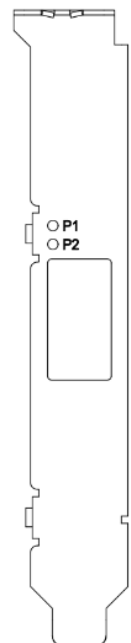

Figure 2: Full length PCIe bracket



## 4.4 Configure the Board

Set the DIP switch settings for proper operation depending on the firmware. Please refer to the section Configuration and DIP Switch for more details.

## 4.5 Install the Adapter Card



Before installing the adapter card, ensure you are properly grounded to avoid static discharges that may destroy your computer or the adapter card. Also, ensure you are grounded before opening your computer or the anti-static bag containing the MXH918. Please follow your computer or expansion chassis manual on installing a PCI Express card.

The MXH918 Adapter card can be installed into any PCI Express x8 or x16 slot and supports PCI Express Gen 1.0, Gen 2.0, Gen 3.0, and Gen 4.0 signaling.

**NOTE: The MXH918 only requires complete electrical x8 signaling from the slot to achieve maximum performance since the edge port is limited to x8.**

## 4.6 Installing and Removing the Cable

Installing and removing cables should be done with the host and expansion system powered off. Please contact the Dolphin representative if you intend to connect and disconnect the PCI Express cables continuously.

### 4.6.1 Connecting the Cable

Please carefully install the cable connector into the connector housing on the MXH918 adapter card. To install the x8 SFF-8644 cable, match the cable house with the connector on the MXH918 adapter card. Use even pressure to insert the connector until it is secure. Adhere to ESD guidelines when installing the cables to ensure you don't damage the board.

### 4.6.2 Cable strain relief

It is crucial to provide strain relief for the PCIe cables to prevent fatigue loading and damage to the card. The cables should be mechanically secured to the rack or cabinet, particularly for long and heavy cables and those between cabinets and racks.

### 4.6.3 Disconnecting the Cable

Please carefully pull the release tab to release the cable from the locking latches and gently pull the cable out of the connector guides.

## 4.7 Installing the Dolphin eXpressWare Software

The MXH918 adapter card is supported by Dolphin's eXpressWare Software package for the MX product line. Please visit

[www.dolphinics.com/mx](http://www.dolphinics.com/mx)

To register and download the latest documentation and software, it is recommended that follow the quick installation instructions found on the website above to install the software for your operating system.

**TIP:** Dolphin provides software and documentation for several product families; **please remember to select the MX product family before downloading.** The MXH918 requires Dolphin software version DIS 5.21.0 or higher to operate. The software download requires a password to log in. **If you follow the instructions on the getting started document bundled with the adapter card, the password will automatically be emailed to you.** If you fail to provide the correct software serial number on the getting started document, your request will be managed manually.

**Note:** Please consult the eXpressWare release note for detailed information on available software functionality. Please get in touch with Dolphin for more information.

## 4.8 Verify Installation & LEDs

The MXH918 has one bi-color LEDs visible through the PCI Express bracket.

The LEDs are visible through cut-outs in the PCIe bracket on one side of the cable connector block.

	Dark	Yellow	Green
Link	Power off, No Cable installed	Power on, No Link	Power on, cable installed; Link operational

**Table 3: LED behaviors**

Each physical x4 connector has a Link LED associated with it.

However, if the configured link width is more than x4, only the single top LED will reflect the link status of the combined ports.

## 5 Operation

### 5.1 Configuration and DIP Switch

The MXH918 has one bank of 4 DIP switches. Its default factory setting is an x8 NTB Host link connection suitable for two-node or three-node configurations.

The MXH918 has DIP switches for setting unique modes or operations; the meaning of each DIP switch depends on the loaded firmware. Please carefully read the documentation shipping with the card before modifying any DIP switch settings. Please pay close attention to the ON and OFF positions on the DIP switch.

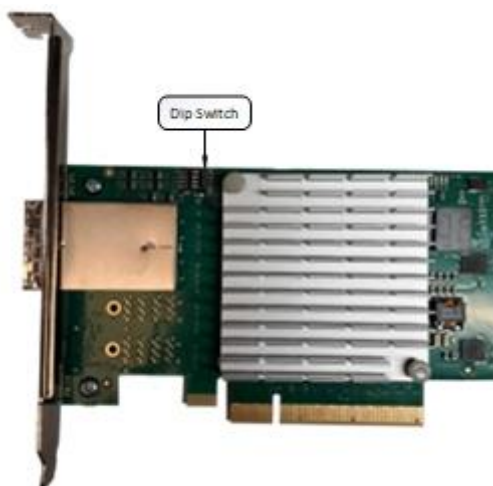

Figure 3: DIP Switch (Shipping Default)

Figure 3 displays the DIP switch utilized by the MXH918 adapter card for configuration purposes. All unlisted DIP switches must be kept in their default positions. For a comprehensive overview of the DIP switch configurations for the MXH918, please refer to Table 4: DIP Switch Settings, which outlines the different transparent settings available.

### 5.2 DIP switch NTB Settings

These are configurations available for MXH918. Please consult the Firmware Release Note for details.







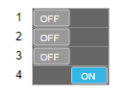

MXH918 DIP Setting	256MB BAR NTB	2GB BAR NTB	32GB BAR NTB	64GB BAR NTB
Single x8 port	 <b>Config#8</b> Shipping Default	 <b>Config#11</b>	 <b>Config#9</b>	 <b>Config#10</b>
Double x4 ports	 <b>Config #12</b>	 <b>Config#15</b>	 <b>Config #13</b>	 <b>Config#14</b>

Table 4: DIP Switch Transparent settings for MXH918.

## 5.3 Use Cases

The MXH918 enable the establishment of various PCIe network configurations in the following Use cases:

### 5.3. Host Transparent Hot Add

Dolphin eXpressWare adds PCIe hot add support with Linux systems. Cabled PCIe expansion systems and IO devices can dynamically be added, hot-swapped or removed from the system without rebooting the host.

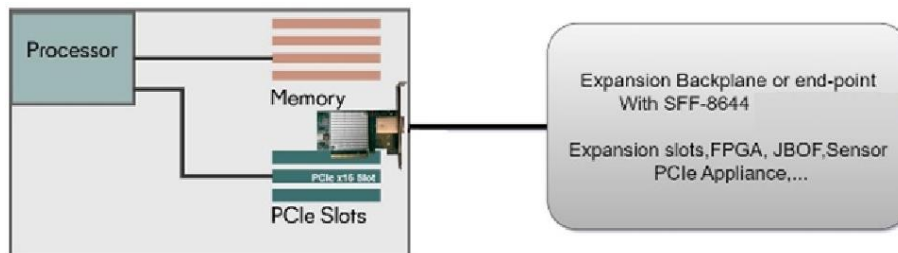

Figure 4: Host Transparent Hot Add

### 5.3.2 Two-Node NTB Network

By utilizing one x8 cable, a robust two-node network can be established, providing full PCIe Gen4 x8 performance between the two connected systems.

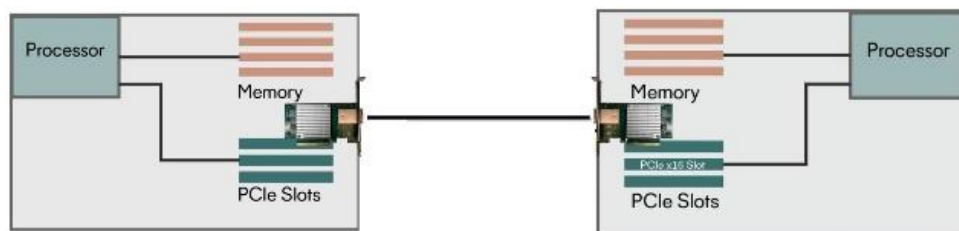

Figure 5: Two-Node Network

### 5.3.2 Three-Node NTB Network

By utilizing x4 cables, a robust 3-node network can be established, providing full PCIe 4.0 x4 performance between the connected systems.

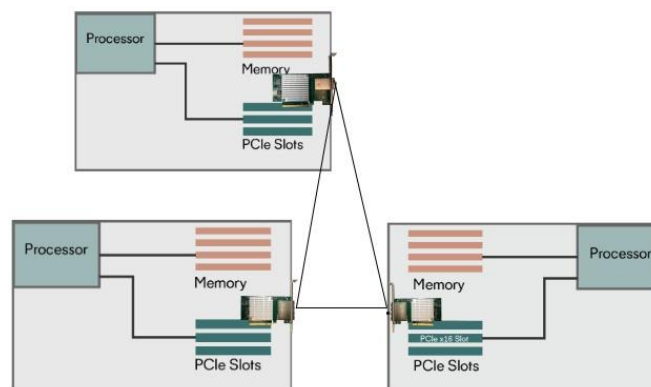

Figure 6: Three-Node Network

### 5.3.3 Multiple-Node Network

One or more Dolphin's MXS924, 24-port PCIe Gen 4.0 Switch can realize a more extensive configuration.

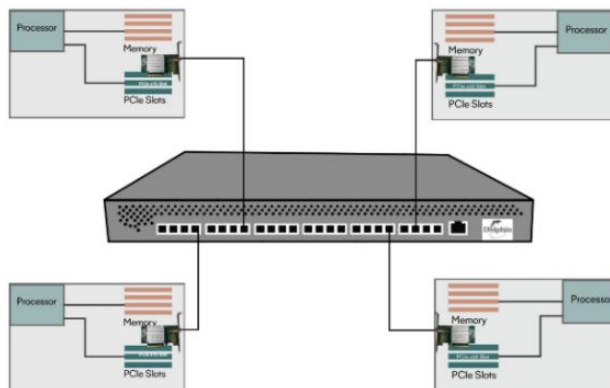

Figure 7: Multiple Node Network

## 5.4 Firmware Upgrade

Periodically, Dolphin might release upgraded firmware accessed through the web or incorporated into the Dolphin software distribution at [www.dolphinics.com/mx](http://www.dolphinics.com/mx).

Please consult the MXH918 Firmware Release Note for information on firmware upgrades.

## 5.5 Identifying the Card

The card has a label sticker with the serial number in the format 'MXH918-YY-ZZZZZZ', where YY denotes the card revision (e.g., BB) and ZZZZZZ denotes the serialised production number (e.g., 012345). This whole string makes up the card's serial number (*i.e.*, MXH918-AA-012345).

You can also get this information using `lspci` in Linux:

First, identify the devices for the Dolphin Host card. Then, run the `lspci` and identify the card.

```
#lspci | grep "Device 4028"
09:00.0 PCI bridge: PMC-Sierra Inc. Device 4028
09:00.1 Memory controller: PMC-Sierra Inc. Device 4028
0a:00.0 PCI bridge: PMC-Sierra Inc. Device 4028
```

Then, run the `lspci` and identify the card. It will show up as something like

```
#lspci -s 09:00.0 -v
09:00.0 PCI bridge: PMC-Sierra Inc. Device 4028 (prog-if 00 [Normal decode])
  Flags: bus master, fast devsel, latency 0, IRQ 40
  Bus: primary=09, secondary=0a, subordinate=0f, sec-latency=0
  I/O behind bridge: 00001000-00002fff [size=8K]
  Memory behind bridge: e8000000-ecffffff [size=80M]
  Prefetchable memory behind bridge: 00000000c0000000-00000000cfffffff [size=256M]
  Capabilities: [40] Express Upstream Port, MSI 00
  Capabilities: [7c] MSI: Enable+ Count=1/8 Maskable- 64bit+
  Capabilities: [8c] Power Management version 3
  Capabilities: [94] Subsystem: Dolphin Interconnect Solutions AS Device 0918
  Capabilities: [100] Advanced Error Reporting
  Capabilities: [148] Power Budgeting <?>
  Capabilities: [158] Multicast
  Capabilities: [188] Secondary PCI Express
  Capabilities: [1b4] Device Serial Number 00-00-42-42-00-00-00-19
  Capabilities: [1c0] Latency Tolerance Reporting
  Capabilities: [1c8] Access Control Services
  Capabilities: [1f0] Data Link Feature <?>
  Capabilities: [1fc] Physical Layer 16.0 GT/s <?>
  Capabilities: [23c] Lane Margining at the Receiver <?>
  Capabilities: [7f8] Vendor Specific Information: ID=ffff Rev=1 Len=808 <?>
  Kernel driver in use: dis-mx-p2p
#lspci -s 09:00.0 -v | grep -E "Subsystem|Serial"
  Capabilities: [94] Subsystem: Dolphin Interconnect Solutions AS Device 0918
  Capabilities: [1b4] Device Serial Number 00-00-41-41-00-00-00-19
```

This shows the card as revision 0x4141 (hexadecimal values of the 'AA' letters in the ASCII table), with the production number 0x00000019 (0000025 in decimal)

## 6 PCIe Cable Port

### 6.1 PCIe Cable Signals

The external PCI Express cable connector supports the following signals:

Signal Type	Description
PETpN/PETnN	PCI Express Transmitter pairs, labeled where N is the Lane number (starting with 0);
PERpN/PERnN	PCI Express Receiver pairs, labeled where N is the Lane number (starting with 0);
CPRSNT#	Cable present signal, active low. Only used in the connector, not routed through the cable.
CADDR	Cable Address signal, active low.
CINT#	Management interface interrupt signal. Only used in the connector, not routed through the cable
CMISDA	The management interface data line is used for communicating with components in the cable assembly. The MXH918 does not support CMI
CMISCL	The management interface clock line is used for communicating with components in the cable assembly. The MXH918 does not support CMI
PWR	+3.3 V Power: Power provisioning to the connector back shell allows active signal conditioning components in the cable assembly. Only used in the connector, not routed through the cable.
MGTPWR	+3.3V management power. Free side power input for management interface circuitry. Only used in the connector, not routed through the cable.
GND	Ground Reference for PCI Express signals, sidebands, and power.

Table 5: PCIe Cable Port Signals

### 6.2 PCIe Cable Connector x8 Pin-Out

	Pin	9	8	7	6	5	4	3	2	1
CONNECTOR 1	D	GND	PETn2	PETp2	GND	PETn1	PETp1	GND	MGTPWR	PWR
	C	GND	PETn3	PETp3	GND	PETn0	PETp0	GND	CMISDA_1	CMISCL_1
	B	GND	PERn2	PERp2	GND	PERn1	PERp1	GND	CBLPRSNT#_1	PWR
	A	GND	PERn3	PERp3	GND	PERn0	PERp0	GND	CINT#_1	CADDR_1
CONNECTOR 2	D	GND	PETn6	PETp6	GND	PETn5	PETp5	GND	MGTPWR	PWR
	C	GND	PETn7	PETp7	GND	PETn4	PETp4	GND	CMISDA_2	CMISCL_2
	B	GND	PERn6	PERp6	GND	PERn5	PERp5	GND	CBLPRSNT#_2	PWR
	A	GND	PERn7	PERp7	GND	PERn4	PERp4	GND	CINT#_2	CADDR_2

Table 6: External PCIe x8 cable pin-out

---

## 7 Compliance and Regulatory Testing

### 7.1 EMC Compliance

The Dolphin PCI ExpressMXH918 adapter is tested to PASS the following relevant test standards for PCI Express cards, telecommunication and industry equipment installed in a standard PC:

- EN 55032:2012,
- EN 55035:2017,
- EN 61000-3-2:2014,
- EN 61000-3-3:2013
- 47 CFR Part 15, Subpart B (Clause 15.107 and 15.109) in conjunction with ANSI C63.4:2014
- CISPR 35:2016 Edition 1.0 (CISPR/I/412/CDV) Korean Harmonized standard, KN 35

This does not ensure that it will comply with these standards in any random PC. The integrator is responsible for ensuring that their products comply with all regulations where they will be used.

### 7.2 FCC Class A

After conducting tests, this device has been determined to conform to the Class A digital device regulations specified in part 15 of the FCC Rules.

### 7.3 RoHS Compliance

The DolphiMXH918 is RoHS compliant. A Compliance certificate issued by the manufacturer is available upon request.

### 7.4 WEEE Notice

The adapter card bears the label following European Directive 2002/96/EC, which pertains to waste electrical and electronic equipment (WEEE). This directive outlines the guidelines for properly disposing and recycling used appliances within the European Union. The presence of this label on the product signifies that it should not be discarded but returned to an approved local WEEE waste collector.





---

## 8 Limited Warranty

Dolphin Interconnect Solutions warrants this product to be free from manufacturing defects under the following terms:

### 8.1 Warranty Period

Dolphin warrants the product for one (1) year from the date of purchase. Extended warranties are available.

### 8.2 Coverage

To the extent permitted by applicable law, this warranty does not apply to:

- Damages caused by operator error or non-compliance with instructions available for the product.
- Use or attempt to use or program firmware not approved by Dolphin.
- Damage which results from accident, abuse, misuse, neglected improper handling or improper installation; moisture, corrosive environments, missing cable strain-relief, high voltage surges, shipping, or abnormal working conditions.
- Damages result from violating the specified operating or storage temperatures and airflow.
- Damage is caused by acts of nature, e.g., floods, storms, fires, or earthquakes.
- Damage caused by any power source out of range or not provided with the product.
- Normal wear and tear.
- Attempts to repair, modify, open, or upgrade the product by personnel or agents not authorized by Dolphin.
- Products that have had the product serial number tampered with or removed.
- Damage to the product caused by products not supplied by Dolphin.

### 8.3 Service Procedure

Suppose the product proves defective during the Warranty Period. In that case, you should contact the seller who supplied you with the product. If you purchased it directly from Dolphin, please check [www.dolphinics.com/support](http://www.dolphinics.com/support) for a valid RMA number and instructions. Products returned to Dolphin without a valid RMA number will not be serviced under this warranty.

## 9 Support

If you need support using the product or have any technical questions, please create a support ticket at [www.dolphinics.com/csp](http://www.dolphinics.com/csp) - We are not able to answer technical questions via email.